

Precise measurement of hyperfine structure in the $5P_{3/2}$ state of ^{85}Rb

U.D. Rapol, A. Krishna, and V. Natarajan^a

Department of Physics, Indian Institute of Science, Bangalore 560 012, India

Received 6 March 2003

Published online 15 April 2003 – © EDP Sciences, Società Italiana di Fisica, Springer-Verlag 2003

Abstract. We demonstrate a technique to measure hyperfine structure using a frequency-stabilized diode laser and an acousto-optic modulator locked to the frequency difference between two hyperfine peaks. We use this technique to measure hyperfine intervals in the $5P_{3/2}$ state of ^{85}Rb and obtain a precision of 20 kHz. We extract values for the magnetic-dipole coupling constant $A = 25.038(5)$ MHz and the electric-quadrupole coupling constant $B = 26.011(22)$ MHz. These values are a significant improvement over previous results.

PACS. 32.10.Fn Fine and hyperfine structure – 42.55.Px Semiconductor lasers; laser diodes – 42.62.Fi Laser spectroscopy

The use of tunable diode lasers has revolutionized the field of atomic physics [1] and particularly laser spectroscopy. The D -lines of most alkali atoms can be conveniently accessed using diode lasers. Therefore, they have been used extensively on alkali atoms as tools for pump-probe spectroscopy, optical-pumping experiments, quantum optics, and the study of three-level systems. They find widespread use in experiments on laser cooling and Bose-Einstein condensation of alkali atoms. They have also been proposed as potential low-cost alternatives for optical-frequency standards [2]. We have been exploring the use of diode lasers for precise measurements of hyperfine intervals in the excited state of alkali atoms. Precise knowledge of hyperfine intervals provides valuable information about the structure of the nucleus (nuclear deformation) and its influence on atomic wavefunctions [3, 4]. The exact knowledge of atomic wavefunctions is particularly important in alkali atoms because of their use in experiments such as atomic signatures of parity violation [5].

In this paper, we demonstrate the use of a single diode laser and an acousto-optic modulator (AOM) for precise hyperfine-structure measurements in the excited state of Rb. In our technique, the laser is first locked to a given hyperfine transition. The laser frequency is then shifted using the AOM to another hyperfine transition and the AOM frequency is locked to this frequency difference. Thus the AOM frequency directly gives a measurement of the hyperfine interval. We demonstrate a precision of 20 kHz in the measurement of the intervals in Rb. Other techniques [3] such as level crossing, double resonance, or using sta-

bilized Fabry-Perot cavities have accuracy limited to the MHz level. So far, the most precise hyperfine measurements have been done in the $5P_{3/2}$ state of ^{87}Rb by Ye *et al.* [2]. In their method, two ultra-stable Ti-sapphire lasers are locked to different hyperfine peaks with an accuracy of 1/2000th of the line center. The beat frequency of the two lasers is measured on a fast photodiode to obtain the hyperfine interval with a precision of 10 kHz. The stability of the laser lock in our technique is only of order 1/20th of the line center, but we are still able to achieve high precision because the two laser beams are derived from the same laser and their fluctuations are correlated. Indeed, if we could lock the laser to 1/2000th of the line center, we believe our technique can be pushed below the kHz level.

The schematic of the experiment is shown in Figure 1. The output of the frequency-stabilized diode laser is split into two parts. One part goes into a Rb saturated-absorption spectrometer (SAS1). The output from this spectrometer is used to lock the laser to a given hyperfine transition of the D_2 line ($5S_{1/2} \leftrightarrow 5P_{3/2}$ transitions). The second part goes into an AOM, where the frequency gets shifted, and then the shifted beam goes to a second Rb saturated-absorption spectrometer (SAS2). The frequency shift is adjusted so that the shifted beam is on a neighboring hyperfine transition. The output from the spectrometer is demodulated and fed back to the voltage-controlled oscillator (VCO) of the AOM driver. Thus, the servo loop locks the AOM frequency to the frequency difference between the two hyperfine transitions. The AOM frequency, and hence the hyperfine interval, is read using a frequency counter.

^a e-mail: vasant@physics.iisc.ernet.in

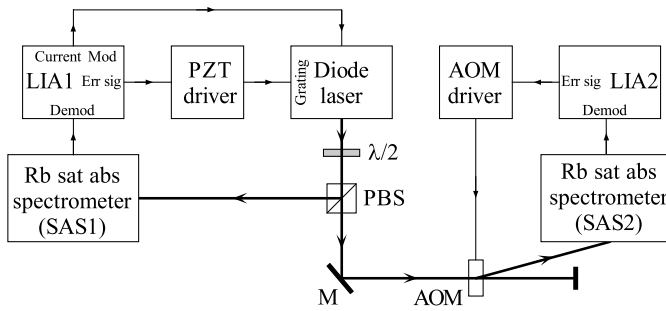

Fig. 1. Schematic of the experiment. The output of the diode laser is fed into two Rb saturated-absorption spectrometers. The error signal from the first is used to lock the laser to a given hyperfine peak. The frequency of the laser is shifted using an AOM and the error signal from the second spectrometer is used to lock the AOM at the frequency difference between the two hyperfine peaks.

The laser is a standard external-cavity diode laser stabilized using optical feedback from a piezo-mounted grating [6, 7]. The r.m.s. linewidth of the laser after stabilization is measured to be below 500 kHz. The AOM produces variable frequency shifts in the range of 75 MHz to 135 MHz, which covers almost all the intervals in the Rb D_2 line. The AOM frequency is measured using a frequency counter whose internal clock is phase locked to a quartz oscillator with a stability of 5 ppm. This stability corresponds to a maximum error of 600 Hz in the measured intervals, which is about two orders of magnitude smaller than the accuracy reported in this work. The intensities of the pump and probe in the saturated-absorption spectrometer are carefully adjusted (to a ratio of about 3) to avoid optical-pumping effects and the effect of velocity redistribution of the atoms in the vapor cell from radiation pressure [8]. Such effects manifest themselves as inversion of hyperfine peaks or distortion of the Lorentzian lineshape. It is important to avoid these effects since they can lead to systematic shifts in the peak position.

The error signals needed for locking are produced by modulating the injection current into the diode laser at a frequency of 18 kHz. The error signal is obtained from the Doppler-subtracted saturated-absorption signal by phase-sensitive detection at the third harmonic of the modulation frequency [9]. This is known to produce narrow error signals that are free from effects due to residual Doppler background or intensity fluctuations. In Figure 2, we show a typical third-harmonic error signal as the laser is scanned across the $F = 3 \rightarrow F'$ transitions of the D_2 line in ^{85}Rb . The various hyperfine components are clearly resolved and labeled according to the value of F' . Crossover resonances that occur exactly half-way between two hyperfine peaks are labeled with the two values of F' in brackets. The depth of modulation of the laser is adjusted to get such sharp error signal with good signal to noise ratio.

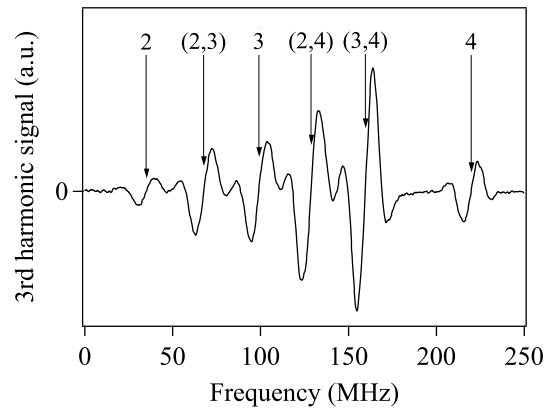

Fig. 2. Error signal for D_2 line of ^{85}Rb . The trace shown is the third-harmonic signal as the laser is scanned across the $F = 3 \rightarrow F'$ transitions. The various hyperfine components are labeled according to the value of F' . The figures in brackets are crossover resonances.

In order to test the reliability of this technique, we have first measured hyperfine intervals in the $5P_{3/2}$ state of ^{87}Rb . These intervals are already known with an accuracy below 10 kHz from the work of Ye *et al.* [2]. Therefore, the measurement acts as a good check on our error budget. In Figure 3, we compare our values with the values reported by Ye *et al.* The values overlap very well at the 1σ level, though our error bars are larger. The error quoted is the sum of the statistical and systematic errors, which is 30 kHz for these measurements. For two intervals, the error is doubled to 60 kHz because we measure only half the interval (using crossover resonances).

With the confidence from the above measurements in ^{87}Rb , we have proceeded to measure hyperfine intervals in ^{85}Rb . The intervals and their measured values are listed in Table 1. The $5P_{3/2}$ state has four hyperfine levels, and thus has only three independent intervals. Therefore, the five measurements listed in Table 1 can be combined in different ways to calculate the three intervals. For example, measurements 3 and 4 are two independent measurements of the same $\{F = 4\} - \{F = 2\}$ interval, but using different hyperfine transitions. The consistency of these two values within the error bars acts as a further check on our error budget. Similarly, the other values have been checked for internal consistency in the determination of the intervals.

^{87}Rb , $5P_{3/2}$ state	Ye <i>et al.</i> [2] (1996)	This work (2002)
3 —————		
2 —————	266.650(9)	266.650(60)
1 —————	156.947(7)	156.880(60)
F = 0 —————	72.218(4)	72.194(30)

Fig. 3. Hyperfine-structure in the $5P_{3/2}$ state of ^{87}Rb . The figure shows a comparison of our measured intervals with earlier results of Ye *et al.* [2].

Table 1. Listed are the various hyperfine intervals measured in this work. The transitions are labeled as $\{F \rightarrow F'\}$, with F' values in brackets representing crossover resonances.

Hyperfine interval	Value (MHz)
1. $\{2 \rightarrow 3\} - \{2 \rightarrow 1\}$	92.68(2)
2. $\{2 \rightarrow 3\} - \{2 \rightarrow (1, 2)\}$	78.05(2)
3. $\{3 \rightarrow (3, 4)\} - \{3 \rightarrow (2, 3)\}$	92.19(2)
4. $\{3 \rightarrow 4\} - \{3 \rightarrow (2, 4)\}$	92.19(2)
5. $\{3 \rightarrow 4\} - \{3 \rightarrow 3\}$	120.96(2)

The values of the three intervals are shown in Figure 4a. Two of these intervals have errors of about 30 kHz after propagating errors from the measured intervals in Table 1.

The dominant source of error in our measurement is the error arising from fluctuations in the lock point of the laser. The gating time of the frequency counter is limited to 10 s, and this results in statistical variation in the measured values. With longer integration times, we believe that this error can be reduced below the kHz level. We have considered the following sources of systematic error and conclude that they are all within the quoted errors. Systematic shifts of the hyperfine peaks due to lineshape modification in the saturated-absorption spectrum (mentioned earlier) are checked by the internal consistency checks described above. Different hyperfine transitions have differing effects (*e.g.* due to optical pumping) and suffer varying shifts. Similarly, the consistency of our results for ^{87}Rb with the results of Ye *et al.* [2] check for these errors. Systematic errors could arise from spectral line shifts due to background collisions in the Rb vapor cells and magnetic-field inhomogeneity in the vicinity of the cells. At the vapor pressure inside the cell (corresponding to an atomic density of $\sim 10^9$ atoms/cc), collisional shifts are estimated to be below 10 kHz. We have measured the magnetic-field inhomogeneity to be below $10 \mu\text{T}$. We have further verified that these errors are negligible by repeating the measurements with different Rb vapor cells from different manufacturers at different locations in the laboratory. The measurements were repeated over a period of several months. We conclude that there are no unaccounted systematic errors at this level of precision.

We have used the data in Table 1 to obtain the hyperfine coupling constants in the $5P_{3/2}$ state of ^{85}Rb . The measured intervals are fitted to the magnetic-dipole coupling constant A and the electric-quadrupole coupling constant B . This yields values of $A = 25.038(5)$ MHz and $B = 26.011(22)$ MHz. In Figure 4a, we show the good agreement between the measured intervals and the intervals calculated from the fitted constants. In Figure 4b, these A and B values are compared to earlier values reported by Arimondo *et al.* [3] and Barwood *et al.* [11]. The recommended values of Arimondo *et al.* are obtained from a global fit to all available spectroscopic data. Our value of A just overlaps with this value, but with 4 times smaller error. Our value of B has slightly smaller error, but the overlap is only at the 2σ level. The more recent values from

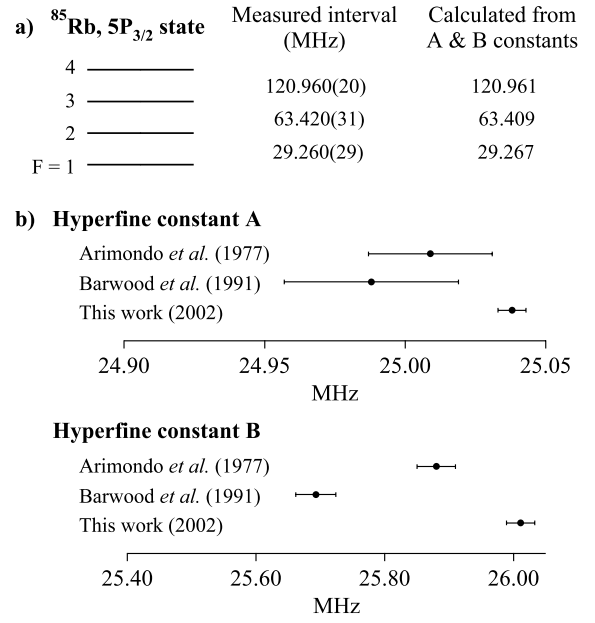
**Fig. 4.** Hyperfine-structure in the $5P_{3/2}$ state of ^{85}Rb . In (a), we compare the measured hyperfine intervals with values calculated from the fitted constants. In (b), we compare our A and B values with the earlier values reported by Arimondo *et al.* [3] and Barwood *et al.* [11].

Barwood *et al.* are consistent for A , but are quite different from both the recommended value for B , and our result, suggesting the need for future measurements with higher precision.

In conclusion, we have demonstrated a new technique for measuring hyperfine intervals in alkali atoms using a single frequency-stabilized diode laser. An acousto-optic modulator locked to the frequency difference between two hyperfine transitions gives absolute frequency calibration for the measurement. Using this technique, we have demonstrated 20 kHz precision in the measurement of hyperfine intervals in ^{85}Rb . The statistical error is primarily limited by the gating interval of our frequency counter and we hope to improve this in the future. We also plan to reduce the linewidth of our diode lasers below 10 kHz using optical feedback from a high- Q resonator [10]. The linewidth of the hyperfine peaks in the saturated-absorption spectrometer is about 2 to 3 times the natural linewidth and is probably limited by power broadening and beam overlap in the cell. By reducing the linewidth close to the natural linewidth, we hope to achieve 3 kHz stability in the laser locking, similar to what has been reported in reference [2]. This should enable us to achieve sub-kHz precision for the intervals, which is an unprecedented level of precision in the measurement of hyperfine intervals of excited states.

This work was supported by the Department of Science and Technology, Government of India.

References

1. J.C. Camparo, *Contemp. Phys.* **26**, 443 (1985)
2. J. Ye, S. Swartz, P. Jungner, J.L. Hall, *Opt. Lett.* **21**, 1280 (1996)
3. E. Arimondo, M. Inguscio, P. Violino, *Rev. Mod. Phys.* **49**, 31 (1977)
4. S.A. Blundell, W.R. Johnson, J. Sapirstein, *Phys. Rev. A* **43**, 3407 (1991)
5. C.S. Wood, S.C. Bennett, D. Cho, B.P. Masterson, J.L. Roberts, C.E. Tanner, C.E. Wieman, *Science* **275**, 1759 (1997)
6. K.B. MacAdam, A. Steinbach, C. Wieman, *Am. J. Phys.* **60**, 1098 (1992)
7. A. Banerjee, U.D. Rapol, A. Wasan, V. Natarajan, *Appl. Phys. Lett.* **79**, 2139 (2001)
8. R. Grimm, J. Mlynek, *Appl. Phys. B.* **49**, 179 (1989)
9. A.J. Wallard, *J. Phys. E* **5**, 926 (1972)
10. B. Dahmani, L. Hollberg, R. Drullinger, *Opt. Lett.* **12**, 876 (1987)
11. G.P. Barwood, P. Gill, W.R.C. Rowley, *Appl. Phys. B* **53**, 142 (1991).